

24





HERRAMIENTA PARA MADERA
TOOLS FOR WOOD
OUTILLAGE POUR LE BOIS
WERKZEUGE FÜR HOLZ
UTENSILI PER LEGNO
FERRAMENTAS PARA MADEIRA
ИНСТРУМЕНТ ДЛЯ ДЕРЕВА



■ FORMONES / FIRMER CHISELS / CISEAUX À BOIS / STECHBEITEL / SCALPELLI / FORMOES / СТАМЕЦКИ

Hoja de acero especial, rectificada / Precision machined steel blade / En acier special trempé et poli / Geschliffene stechbeitel aus spezialstahl / Lama-inacciaio speciało rettificata / Lâmina de aço especial rectificada / Стальная режущая часть сверхточной обработки

■ TITACROM® BIMAT

COD.				
67169	6	130		
67170	8	135		
67171	10	140		
67172	12	145		
67173	14	150		
67174	15	155		
67175	16	160	12	•
67176	18	170		
67177	20	175		
67178	22	180		
67179	25	190		
67180	30	200		
67181	32	210		



TITACROM® BIMAT | DIN 5139

■ EXPOSITORES / DISPLAYS / PRESENTOIRS / DISPLAY / ESPOSITORI / EXPOSIÇÃO INDIVIDUAL / СТЕНДЫ

■ TITACROM® BIMAT

■ 60 PCS.

COD.	PCS.
55665	60

PCS.	COD. PCS.	
6	67169	6
	67170	8
	67171	10
	67172	12
	67174	15
	67176	18
	67177	20
	67178	22
	67179	25
	67180	30



■ KITS

■ TITACROM® BIMAT

■ 4 PCS.



COD.	PCS.
69481	4

PCS.	COD. PCS.	
1	67171	10
	67172	12
	67174	15
	67176	18



• Presentador individual / Individual display / Conditionnement unitaire

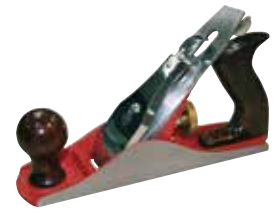

■ **CEPILLOS / JACK PLANES / RABOTS / SCHLICHTHOBEL / PIALLA / PLAINAS / РУБАНКИ**

COD.	L (mm)			
67052	350	2,0	1	64239



■ **SARGENTOS / CLAMPS / SERRE-JOINTS / ZWINGEN / MORSETTI SERRAGIUNTI / GRAMPOS / СТРУБЦИНЫ**

■ **MOD. G**



COD.	A max (mm)	B (mm)			Kgf *
69570	50	30	195	6	120
69571	75	52	700	6	150
69572	100	60	900	4	255
69574	150	65	1600	3	355
69575	200	83	1900	3	400

CARACTERÍSTICAS / FEATURES / CARACTÉRISTIQUES

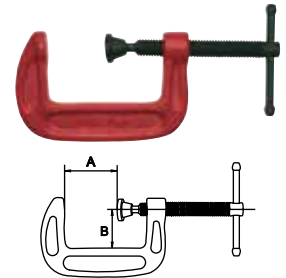
Kgf: fuerza de amarre / Kgf: fastening force / Kgf: force de serrage



■ **MOD. F**



COD.	A max (mm)	B (mm)			Kgf
69580	150	50	450	6	225
69581	200	50	600		
69582	250	80	1000		
69583	300	80	1150		
69585	400	80	1800		
69586	400	120	1800	2	600
69588	600	120	2200		
69589	800	120	2700		
69590	1000	120	3000		

CARACTERÍSTICAS / FEATURES / CARACTÉRISTIQUES

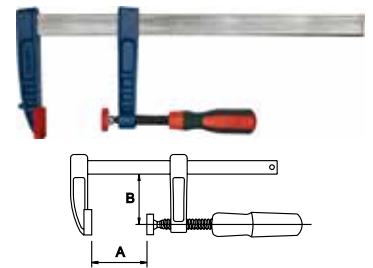
Kgf: fuerza de amarre / Kgf: fastening force / Kgf: force de serrage



■ **FORJADO / FORGED / FORGÉ / GESCHMIEDET / FORGIATO / FORJADO / ЗАКАЛЕННАЯ**

COD.	A max (mm)	B (mm)	C (mm)	D (mm)			Kgf
69961	250	80	6	15,5	650	6	255
69965		80	6	15,5	900		
69967	400	100	9,5	19	1200	2	300
69968	500	100	9,5	19	1600		
69970	250	120	10	21,5	1100		
69972	400	120	10	21,5	1400		
69975	800	120	10	21,5	1900	2	400
69977	1200	120	10	21,5	2900		

CARACTERÍSTICAS / FEATURES / CARACTÉRISTIQUES

Kgf: fuerza de amarre / Kgf: fastening force / Kgf: force de serrage

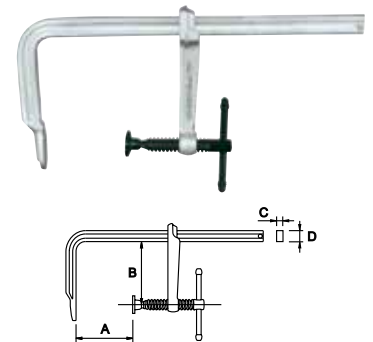

PROYECTOS PRINCIPALES

MAIN PROJECTS

PRINCIPAUX PROJETS

**CENTRAL HIDROELÉCTRICA DATENXIA / DATENXIA HYDROPOWER
STATION / CENTRALE HYDROÉLECTRIQUE DATENXIA**
CON EGAWARE / WITH EGAWARE / AVEC EGAWARE
CHINA / CHINE

